

REVISION		DATE	APPROVED
REV	ECO	DESCRIPTION	
X5	UPDATED	9/27/12	H. BAIK

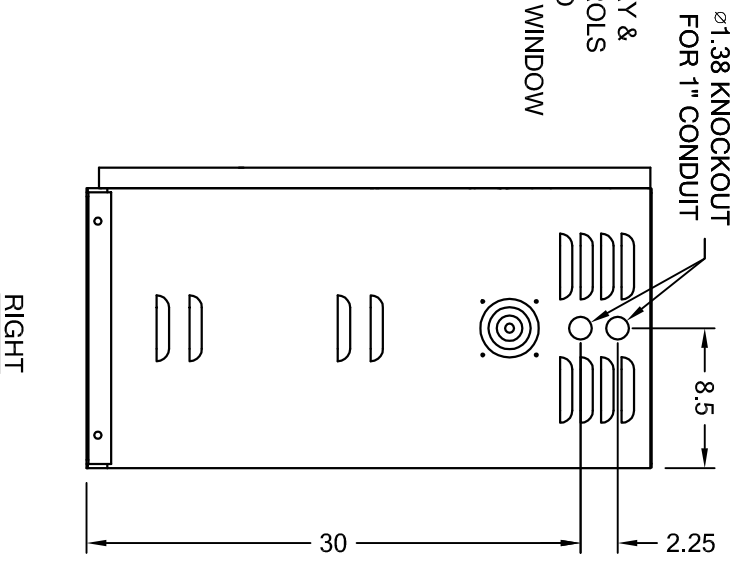

- NOTES: (UNLESS OTHERWISE SPECIFIED)
- 1) ALL DIMENSIONS SHOWN ARE APPROXIMATE.
 - 2) ENCLOSURE: INDOOR NEMA TYPE 1, COLOR BLACK.
 - 3) DRAWING SHOWN WITH OPTIONAL SEISMIC.
 - 4) RATING: FROM 500 W. TO 2100 W.
 - 5) WEIGHT: FROM 265 LBS UP TO 760 LBS (WITH BATTERIES).

<input type="checkbox"/> APPROVED <input type="checkbox"/> DISAPPROVED		DATE:
<input type="checkbox"/> APPROVED WITH COMMENTS		
COMMENTS:		
NAME:		
SIGNATURE:		
<small>UNLESS OTHERWISE SPECIFIED, DIMENSIONS ARE IN INCHES. TOLERANCES ARE: DECIMALS FRACTIONS ANGLES .XX ±.03 ± 1/64 ± 1/2° .XXX ±.010</small>		
DRWN: HAI NGUYEN	1/27/10	PERFECT POWER SYSTEMS VALUSINE
CHKD: HAI NGUYEN	1/27/10	
APPVD: H. BAIK	1/27/10	SIZE DWG: B 6001-135P SCALE: EST. WT: REV: X5 SHT 1 OF 1
<small>SPECIFICATIONS SUBJECT TO CHANGE WITHOUT NOTICE</small>		

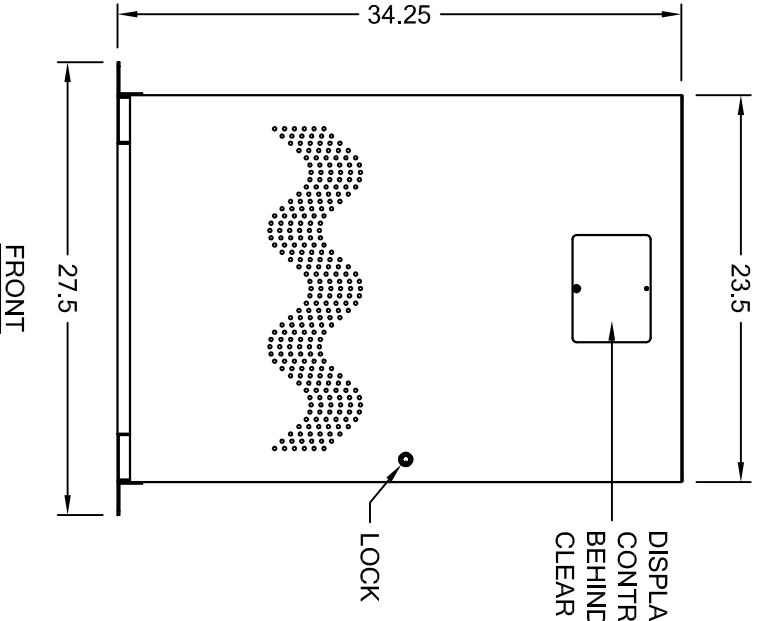
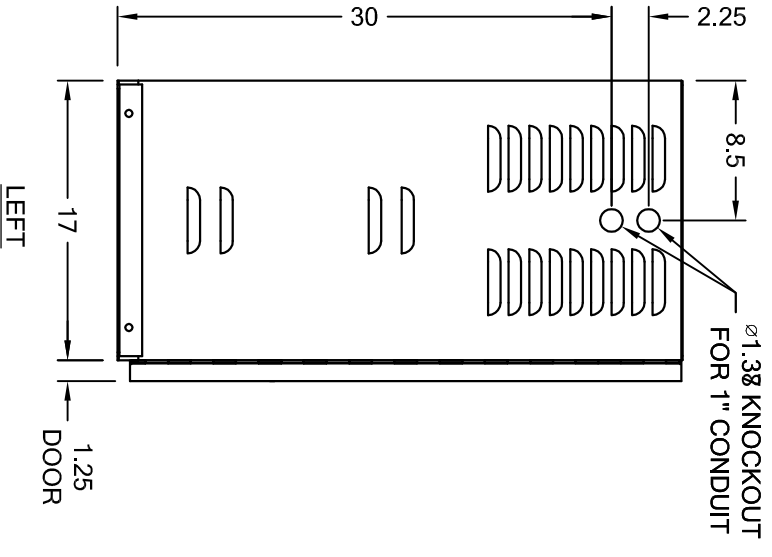
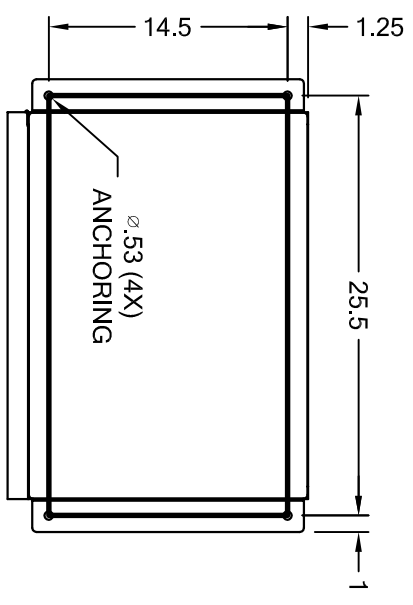
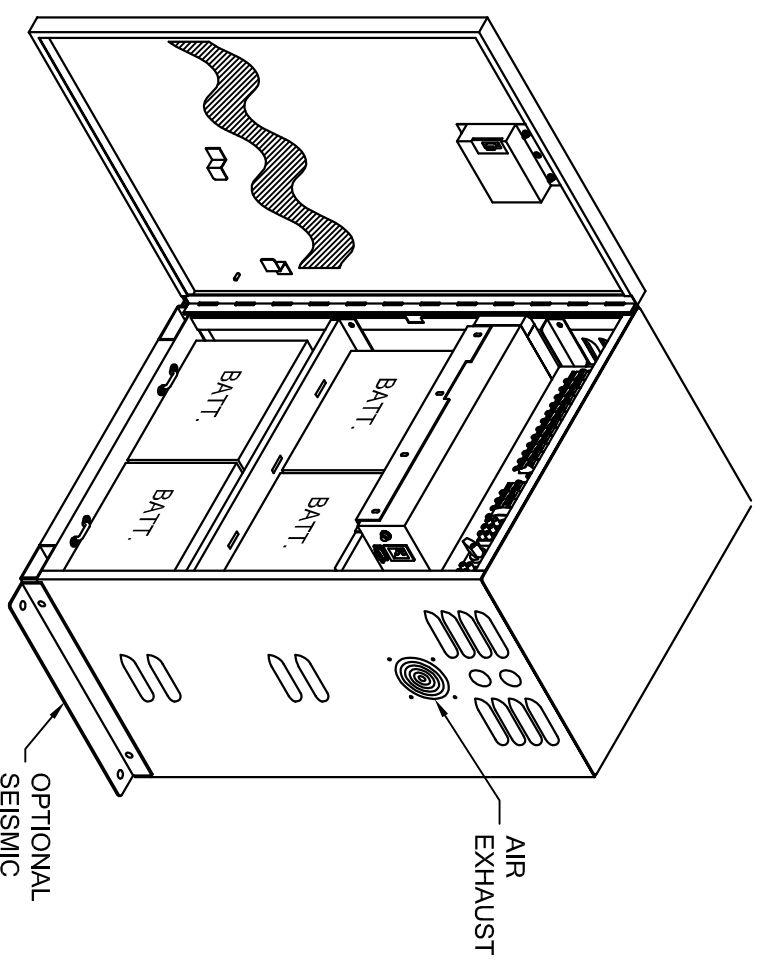
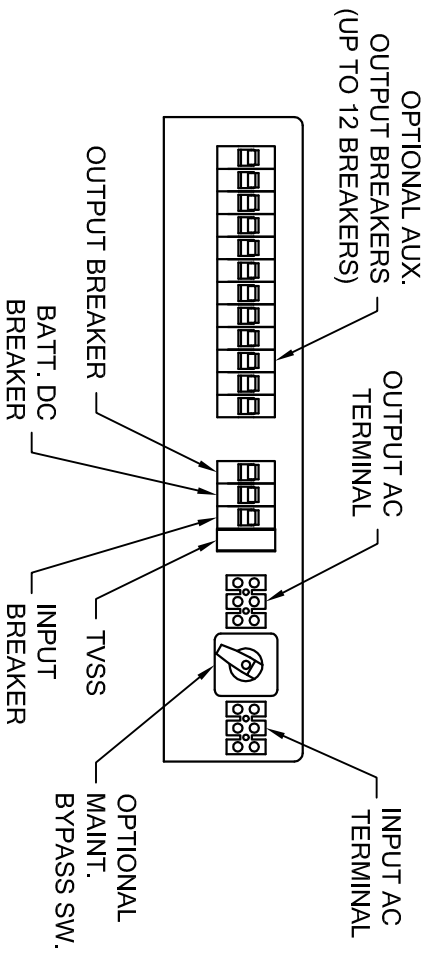
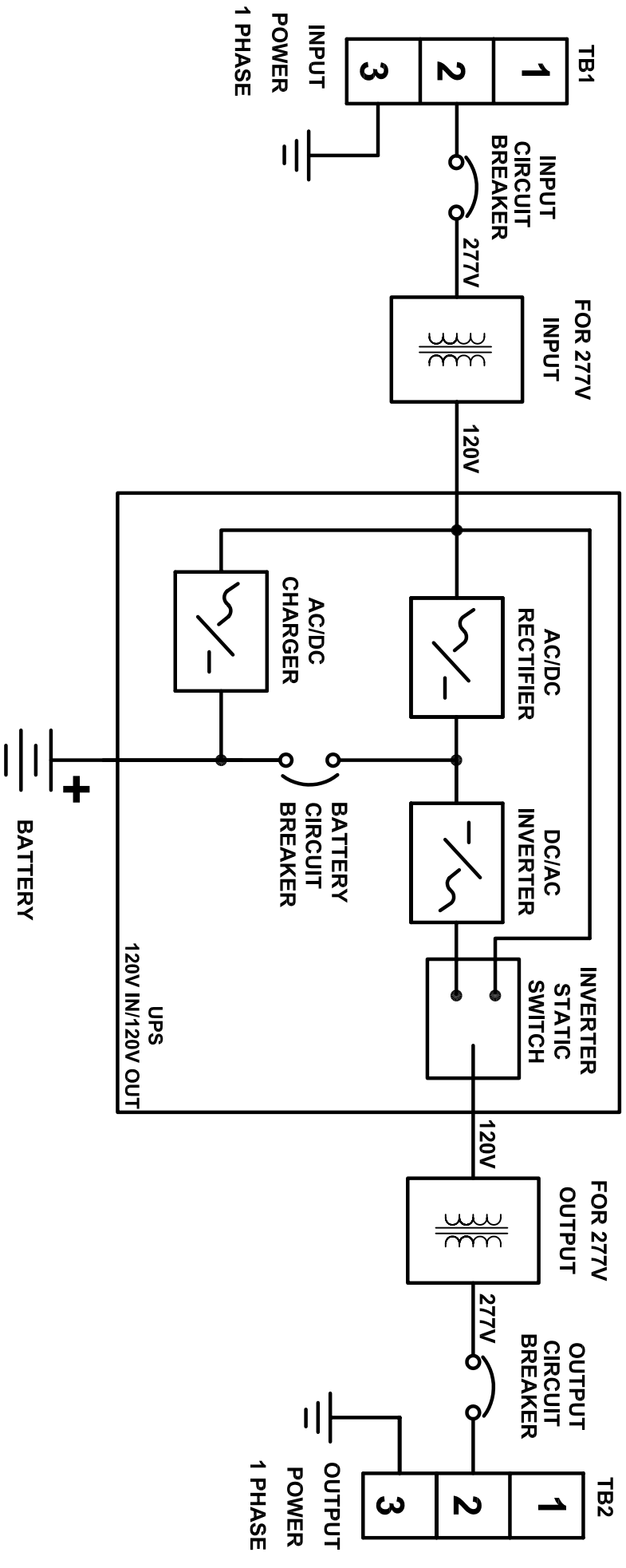

REVISION				
REV	ECO	DESCRIPTION	DATE	APPROVED
A	11089	NEW RELEASE	3/3/16	

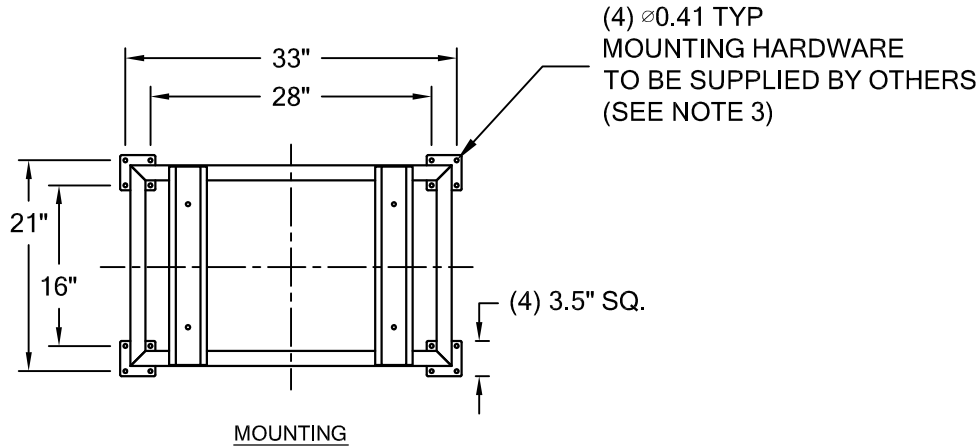

NOTES:

- 1) FINISH: POWDER COAT BLACK FINE TEXTURE.
- 2) MOUNTING HARDWARE TO INSTALL UNIT TO STAND IS PROVIDED WITH THE KIT.
- 3) MOUNTING HARDWARE FOR STAND TO THE FLOOR TO BE SUPPLIED BY OTHERS, (CONSULT APPLICABLE CODES FOR HARDWARE TYPE AND LENGTH BASED ON TYPE OF FLOOR).

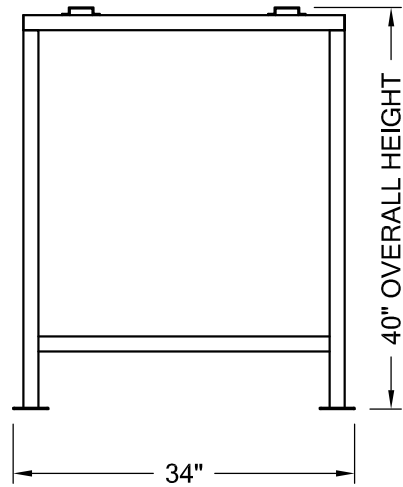

FRONT VIEW

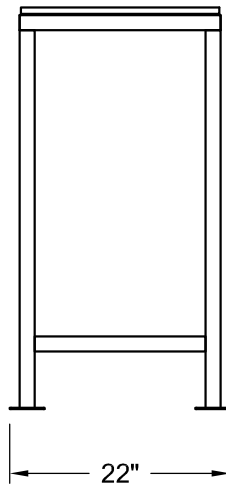

SIDE VIEW

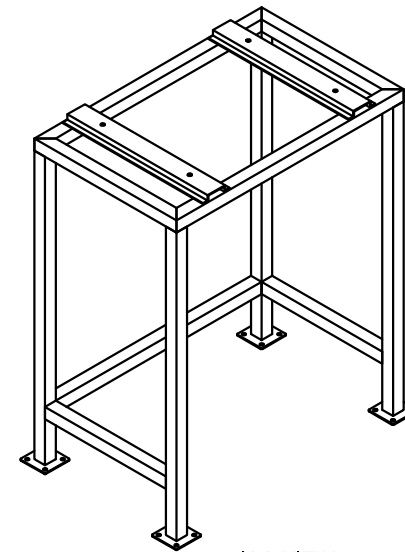

ISO VIEW

<input type="checkbox"/> APPROVED <input type="checkbox"/> DISAPPROVED <input type="checkbox"/> APPROVED WITH COMMENTS		DATE:	UNLESS OTHERWISE SPECIFIED, DIMENSIONS ARE IN INCHES. TOLERANCES ARE: DECIMALS FRACTIONS ANGLES .XX \pm .03 \pm 1/64 \pm 1/2" .XXX \pm .010		PERFECT POWER SYSTEMS COMMERCE, CA	
COMMENTS: _____ _____ _____			CADD: S.SHAHSAVARI	3/3/16	TITLE 40" HEIGHT STAND (STACKABLE) POWER GUARD	
			CHKD:	H.N	3/3/16	SIZE DWG A 6001-360P
NAME:			SIGNATURE:	APPVD:	H.BAIK	SCALE: EST. WT: SHT 1 OF 1
SPECIFICATIONS SUBJECT TO CHANGE WITHOUT NOTICE						